

TECHNICAL SPECIFICATIONS

G4 CUTTER

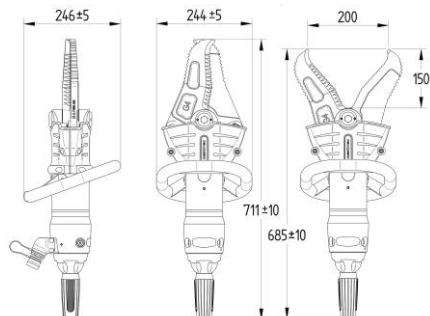

G4 CUTTER

NEO1 

HP/FF 

Nominal pressure	Optimized 350 bar	Optimized 350 bar
Tailhose safety factor	-	8:1 (2,800 bar)
Dimensions (L x W x H)	711 x 244 x 246 mm	711 x 244 x 246 mm
Operational weight	12.6 kg	12.8 kg
Max. cutting opening	200 mm	200 mm
Reach	150 mm	150 mm
Max. cutting force	488 kN / 49.7 ton	488 kN / 49.7 ton
EN 13204	CC 200H-13	CC 200H-13
NFPA 1936	A6 B7 C6 D7 E7	A6 B7 C6 D7 E7

ACCESSORIES

Art. Nr.

LED light add-on

9500.1000



Information contained in this document is believed to be accurate. However RESQTEC does not guarantee the completeness or accuracy of any of the published information.

RESQTEC Zumro B.V.

Meer en Duin 82 | 2163 HC Lisse, the Netherlands

T +31 (0)252 419002

E info@resqtec.com

F +31 (0)252 411794

W www.resqtec.com

RESQTEC[®]





CUTTING PERFORMANCE AS PER EN13204 TABLE 3 FOR CUTTERS AND COMBI TOOLS

DU002K00

Manufacturer	RESQTEC
Tool name and type	G4 CUTTER





CLAIMED CLASSIFICATION;

TYPE	CUTTER OPENING	CLASSIFICATION BASED ON MIN CUTTING PERFORMANCE	WEIGHT (1 decimal accurate)	CUTTING PERFORMANCE
CC	200	H	12.8	1H-2H-3H-4H-5H

PROFILE TYPE →	1 Round bar	2 Flat bar	3 Round tube	4 Square tube	5 Rectangular tube
CATEGORY LETTER ↓					
A	≥ 14	30 x 5	21,3 x 2,3		
B	≥ 16	40 x 5	26,4 x 2,3		
C	≥ 18	50 x 5	33,7 x 2,6	35 x 3	
D	≥ 20	60 x 5	42,6 x 2,6	40 x 4	50 x 25 x 2,5
E	≥ 22	80 x 8	48,3 x 2,9	45 x 4	50 x 30 x 3,0
F	≥ 24	80 x 10	60,3 x 2,9	50 x 4	60 x 40 x 3,0
G	≥ 26	100 x 10	76,1 x 3,2	55 x 4	80 x 40 x 3,0
H	≥ 28	110 x 10	76,1 x 4,0	60 x 4	80 x 40 x 4,0
I	≥ 32	120 x 10	88,9 x 4,0	60 x 5	80 x 40 x 5,0
J	≥ 36	130 x 10	88,9 x 5,0	70 x 4	100 x 50 x 4,0
K	≥ 40	140 x 10	101,6 x 4,0	70 x 5	100 x 50 x 5,0

CUTTING PERFORMANCE AS PER NFPA 1936 FOR CUTTERS AND COMBI TOOLS

A6 B7 C6 D7 E7

PROFILE TYPE →	A Round bar		B Flat bar		C Round pipe		D Square tube		E Angle iron		
PERFORMANCE LEVEL ↓											
	inch	mm	inch	mm	inch	mm	inch	mm	inch	mm	
1	3/8	9.5	1/4 x 1/2	6.4 x 13.7	3/8	0.68 x 0.09	17.2 x 2.2	1/2 x 0.06	12.7 x 1.5	1/2 x 1/8	12.7 x 3.17
2	1/2	12.7	1/4 x 1	6.4 x 25.4	3/4	1.05 x 0.11	26.6 x 2.79	1 3/4 x 0.06	19.1 x 1.5	1 x 1/8	25.4 x 3.17
3	5/8	15.8	1/4 x 2	6.4 x 50.8	1	1.32 x 0.13	33.5 x 3.3	1 x 0.08	25.4 x 2	1 1/4 x 3/16	31.7 x 4.8
4	3/4	19.1	1/4 x 3	6.4 x 76.2	1 1/4	1.66 x 0.14	42.2 x 3.2	1 1/4 x 0.12	31.7 x 3	1 1/2 x 3/16	38.1 x 4.8
5	7/8	22.2	1/4 x 4	6.4 x 101.6	1 1/2	1.90 x 0.15	48.3 x 3.2	1 1/2 x 0.12	38.1 x 3	1 1/2 x 1/4	38.1 x 6.35
6	1	25.4	3/8 x 3	9.5 x 76.2	2	2.38 x 0.15	60.5 x 3.8	1 3/4 x 0.12	44.5 x 3	1 3/4 x 1/4	44.5 x 6.35
7	1 1/4	31.8	3/8 x 4	9.5 x 101.6	2 1/2	2.88 x 0.20	73.2 x 5.1	2 x 0.15	50.8 x 3.8	1 1/2 x 3/8	38.1 x 9.5
8	1 1/2	38.1	3/8 x 5	9.5 x 126	3	3.50 x 0.22	88.9 x 5.6	2 1/2 x 0.19	63.5 x 4.6	2 x 3/8	50.8 x 9.5
9	1 3/4	44.45	3/8 x 6	9.5 x 152.4	3 1/2	4.00 x 0.23	101.6 x 5.8	3 x 0.19	76.2 x 4.8	2 1/2 x 3/8	63.5 x 9.5