

TECHNICAL SPECIFICATIONS

G6 CUTTER

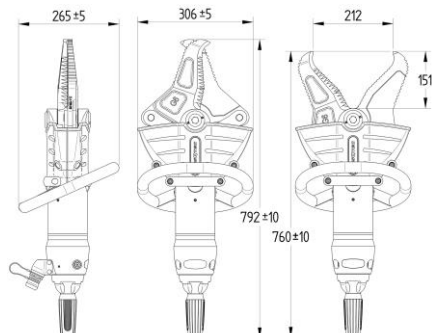

G6 CUTTER

NEO1 

HP/FF 

Nominal pressure	Optimized 350 bar	Optimized 350 bar
Tailhose safety factor	-	8:1 (2,800 bar)
Dimensions (L x W x H)	792 x 306 x 265 mm	792 x 306 x 265 mm
Operational weight	17.7 kg	17.7 kg
Max. cutting opening	212 mm	212 mm
Reach	151 mm	151 mm
Max. cutting force	1,251 kN / 127.5 ton	1,251 kN / 127.5 ton
EN 13204	CC 202H-18	CC 202H-18
NFPA 1936	A8 B8 C7 D8 E8	A8 B8 C7 D8 E8

ACCESSORIES

Art. Nr.

LED light add-on

9500.1000



Information contained in this document is believed to be accurate. However RESQTEC does not guarantee the completeness or accuracy of any of the published information.

RESQTEC Zumro B.V.

Meer en Duin 82 | 2163 HC Lisse, the Netherlands

T +31 (0)252 419002

E info@resqtec.com

F +31 (0)252 411794

W www.resqtec.com

RESQTEC[®]





CUTTING PERFORMANCE AS PER EN13204 TABLE 3 FOR CUTTERS AND COMBI TOOLS

DU003K00

Manufacturer	RESQTEC
Tool name and type	G6 CUTTER





CLAIMED CLASSIFICATION;

TYPE	CUTTER OPENING	CLASSIFICATION BASED ON MIN CUTTING PERFORMANCE	WEIGHT (1 decimal accurate)	CUTTING PERFORMANCE
CC	202	H	17.7	1H-2H-3H-4H-5H

PROFILE TYPE →	1 Round bar	2 Flat bar	3 Round tube	4 Square tube	5 Rectangular tube
CATEGORY LETTER ↓					
A	≥ 14	30 x 5	21,3 x 2,3		
B	≥ 16	40 x 5	26,4 x 2,3		
C	≥ 18	50 x 5	33,7 x 2,6	35 x 3	
D	≥ 20	60 x 5	42,6 x 2,6	40 x 4	50 x 25 x 2,5
E	≥ 22	80 x 8	48,3 x 2,9	45 x 4	50 x 30 x 3,0
F	≥ 24	80 x 10	60,3 x 2,9	50 x 4	60 x 40 x 3,0
G	≥ 26	100 x 10	76,1 x 3,2	55 x 4	80 x 40 x 3,0
H	≥ 28	110 x 10	76,1 x 4,0	60 x 4	80 x 40 x 4,0
I	≥ 32	120 x 10	88,9 x 4,0	60 x 5	80 x 40 x 5,0
J	≥ 36	130 x 10	88,9 x 5,0	70 x 4	100 x 50 x 4,0
K	≥ 40	140 x 10	101,6 x 4,0	70 x 5	100 x 50 x 5,0

CUTTING PERFORMANCE AS PER NFPA 1936 FOR CUTTERS AND COMBI TOOLS

A8 B8 C7 D8 E8

PROFILE TYPE →	A Round bar		B Flat bar		C Round pipe		D Square tube		E Angle iron		
PERFORMANCE LEVEL ↓											
	inch	mm	inch	mm	inch	mm	inch	mm	inch	mm	
1	3/8	9.5	1/4 x 1/2	6.4 x 13.7	3/8	0.68 x 0.09	17.2 x 2.2	1/2 x 0.06	12.7 x 1.5	1/2 x 1/8	12.7 x 3.17
2	1/2	12.7	1/4 x 1	6.4 x 25.4	3/4	1.05 x 0.11	26.6 x 2.79	1 3/4 x 0.06	19.1 x 1.5	1 x 1/8	25.4 x 3.17
3	5/8	15.8	1/4 x 2	6.4 x 50.8	1	1.32 x 0.13	33.5 x 3.3	1 x 0.08	25.4 x 2	1 1/4 x 3/16	31.7 x 4.8
4	3/4	19.1	1/4 x 3	6.4 x 76.2	1 1/4	1.66 x 0.14	42.2 x 3.2	1 1/4 x 0.12	31.7 x 3	1 1/2 x 3/16	38.1 x 4.8
5	7/8	22.2	1/4 x 4	6.4 x 101.6	1 1/2	1.90 x 0.15	48.3 x 3.2	1 1/2 x 0.12	38.1 x 3	1 1/2 x 1/4	38.1 x 6.35
6	1	25.4	3/8 x 3	9.5 x 76.2	2	2.38 x 0.15	60.5 x 3.8	1 3/4 x 0.12	44.5 x 3	1 3/4 x 1/4	44.5 x 6.35
7	1 1/4	31.8	3/8 x 4	9.5 x 101.6	2 1/2	2.88 x 0.20	73.2 x 5.1	2 x 0.15	50.8 x 3.8	1 1/2 x 3/8	38.1 x 9.5
8	1 1/2	38.1	3/8 x 5	9.5 x 126	3	3.50 x 0.22	88.9 x 5.6	2 1/2 x 0.19	63.5 x 4.6	2 x 3/8	50.8 x 9.5
9	1 3/4	44.45	3/8 x 6	9.5 x 152.4	3 1/2	4.00 x 0.23	101.6 x 5.8	3 x 0.19	76.2 x 4.8	2 1/2 x 3/8	63.5 x 9.5